

DIN 95 - Slotted Oval Head Machine Screws Specifications

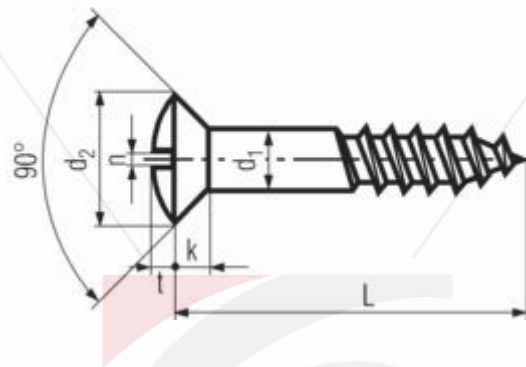

All measurements in millimeters (mm)

d_1	d_2	k max.	n	t min.
M3	5.6	1.65	0.8	1.2
M3.5	6.5	1.93	0.8	1.4
M4	7.5	2.2	1	1.6
M4.5	8.3	2.35	1	1.8
M5	9.2	2.5	1.2	2
M6	11	3	1.6	2.4

FOR INFORMATION PURPOSES ONLY

©Fastener Network Holdings Ltd, Unit B, Grazebrook Industrial Park, Peartree Lane, Dudley, West Midlands, DY2 0XW, United Kingdom

T: +44 (0) 1384 217 600 F: +44 (0) 1384 217 606

www.fastenernetwork.co.uk