

DIN 7982 - Cross Rec. Flat hd Tapping Screws, hd Angle 80

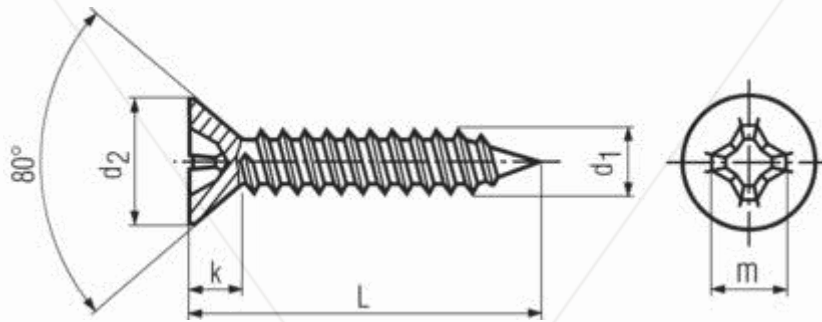

All measurements in millimeters (mm)

| d_1 | d_2 max | k max | m approx. | Cross Recess No. |
|-------|-----------|---------|-------------|------------------|
| 2.2 | 4.3 | 1.3 | 2.5 | H1 |
| 2.9 | 5.5 | 1.7 | 3 | H1 |
| 3.5 | 6.8 | 2.1 | 4.2 | H2 |
| 3.9 | 7.5 | 2.3 | 4.6 | H2 |
| 4.2 | 8.1 | 2.5 | 4.7 | H2 |
| 4.8 | 9.5 | 3 | 5.1 | H2 |
| 5.5 | 10.8 | 3.4 | 6.8 | H3 |
| 6.3 | 12.4 | 3.8 | 7.1 | H3 |
| 8 | 15.8 | 4.65 | - | - |

FOR INFORMATION PURPOSES ONLY

©Fastener Network Holdings Ltd, Unit B, Grazebrook Industrial Park, Peartree Lane, Dudley, West Midlands, DY2 0XW, United Kingdom

T: +44 (0) 1384 217 600 F: +44 (0) 1384 217 606

www.fastenernetwork.co.uk