

DIN 9021 Specification

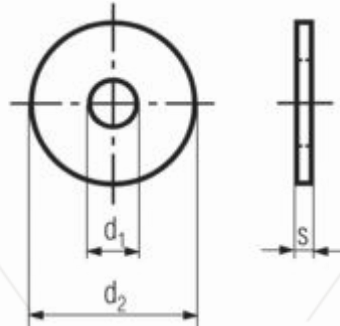

d_1	used for	d_2 max	s
3.2	M3	9	0.8
4.3	M4	12	1
5.3	M5	15	1.2
6.4	M6	18	1.6
8.4	M8	24	2
10.5	M10	30	2.5
13	M12	37	3
15	M14	44	3
17	M16	50	3
20	M18	56	4
22	M20	60	4

All measurements in millimetres (mm)

FOR INFORMATION PURPOSES ONLY

©Fastener Network Holdings Ltd, Unit B, Grazebrook Industrial Park, Peartree Lane, Dudley, West Midlands, DY2 0XW, United Kingdom

T: +44 (0) 1384 217 600 F: +44 (0) 1384 217 606

www.fastenernetwork.co.uk